



DCL SERIES
DIAPHRAGM
ACTUATOR



Features

Operation

Pneumatic diaphragm/spring actuator.
70° or 90° rotation angle without the need for additional parts.

Manual Operator (Optional)

Top handwheel for manual operation can be supplied.

Air Pressure Supply

50 psig maximum.

Sizes and Torques

See tables 1 to 4.

Spring Ranges

Spring standard ranges: 3-15 psig or 12-30 psig.

Main parts identification

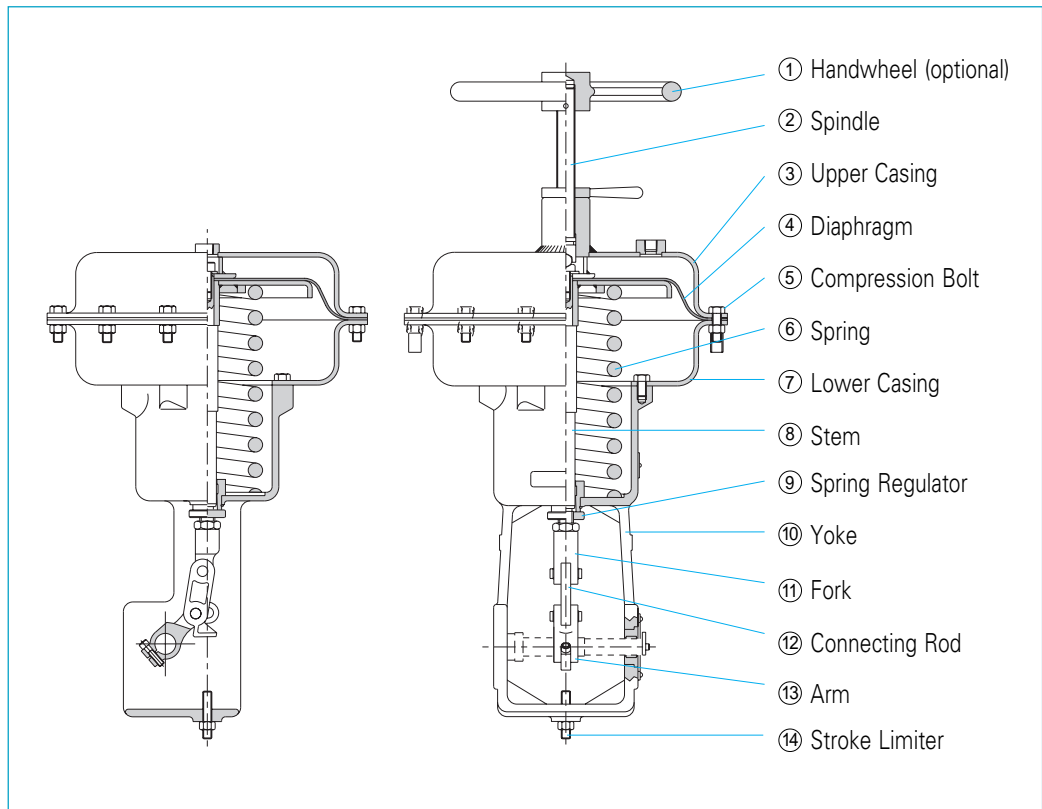

Table 1
Spring torque
at the start
of the travel

ACTUATOR SIZE	SPRING RANGE (psig)			
	3-15		12-30	
	ROTATION			
	70°	90°	70°	90°
TORQUE (lb.-in.)				
02	-	-	195	131
06	127	99	509	397
08	318	196	1272	785
09	587	344	2267	1328
10	920	585	3457	2199

ACTUATOR SIZE	SPRING RANGE (psig)			
	3-15		12-30	
	ROTATION			
	70°	90°	70°	90°
	TORQUE (lb.-in.)			
02	-	-	464	339
06	613	517	1154	948
08	1601	1223	3043	2345
09	2929	2357	5364	4317
10	4947	3736	8245	6228

Table 2
Spring torque at the end of the travel

ACTUATOR SIZE	SPRING RANGE (psig)								
	3-15					12-30			
	EFFECTIVE AIR SUPPLY PRESSURE AT ACTUATOR (psig)								
	20	25	30	35	40	45	35	40	45
	TORQUE (lb.-in.)								
02	-	-	-	-	-	-	109	191	273
06	307	537	767	997	1227	1457	457	687	917
08	785	1381	1978	2575	3171	3768	1132	1728	2325
09	1337	2404	3471	4538	5605	6672	1836	2864	3893
10	2205	3993	5782	7570	9538	11146	3510	5189	6869

Table 3
Resulting torque from the difference between air supply force and spring force for a 70° opening angle

ACTUATOR SIZE	SPRING RANGE (psig)								
	3-15					12-30			
	EFFECTIVE AIR SUPPLY PRESSURE AT ACTUATOR (psig)								
	20	25	30	35	40	45	35	40	45
	TORQUE (lb.-in.)								
02	-	-	-	-	-	-	79	139	199
06	197	376	554	733	912	1091	303	481	660
08	607	1067	1527	1987	2447	2908	875	1335	1795
09	1077	1936	2794	3653	4512	5371	1478	2306	3134
10	1665	3016	4367	5717	7068	8418	2651	3919	5188

Table 4
Resulting torque from the difference between air supply force and spring force for a 90° opening angle

Remark: Before using tables 1,2,3 and 4 add at least 25% to the valve required torque.

Normally opened valve

Stroke: 70°

Valve torque: 800 lb.-in.

An actuator torque at least 25% higher than valve torque requirement is recommended.

Required actuator torque: 1000 lb.-in.

Required torque, at opening, will be supplied by the spring at the end of the stroke, and at closing by the difference between air supply pressure and spring forces. By referring to table 2, we can see that a DCL size 06 actuator with a 12-30 psig spring range or a size 08 actuator with 3-15 psig spring range can be used; however, we should also refer to table 3 that shows that the DCL size 06 actuator does not meet the required condition. We should

therefore select a size 08 actuator with 3-15 psig spring range and an effective air supply pressure of 25 psig or higher, at the actuator.

Normally closed valve

Stroke: 70°

Valve torque: 240 lb.-in.

An actuator torque at least 25% higher than valve torque requirement is recommended.

Required actuator torque: 300 lb.-in.

Required torque will be supplied by the spring at the beginning of the stroke. By referring to table 1, we can see that a DCL size 06 actuator with a 12-30 psig spring range, or a size 08 actuator with 3-15 psig spring range, can be used.

Actuator selecting examples

Dimensions

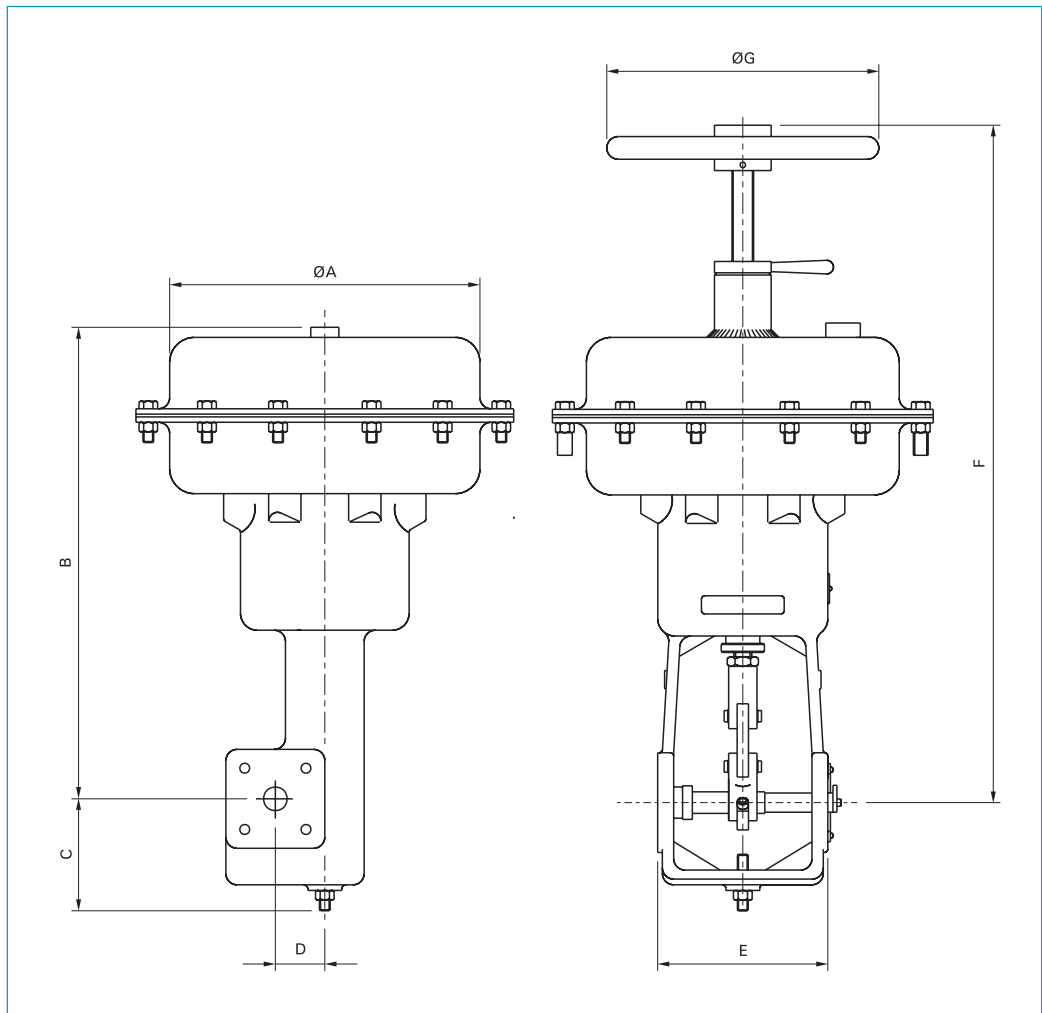

SIZE	DIMENSIONS (mm)						
	A	B	C	D	E	F	ØG
02	190	228	80	26.6	120	333	165
06	285	353	88	26.6	120	553	235
08	336	419	108	44.3	150	620	235
09	410	498	125	53.2	180	713	350
10	476	588	148	62	220	838	480

Accessories

Pneumatic positioner, electro-pneumatic positioner, smart positioner, air filter/regulator, limit switch, electro-pneumatic transducer, solenoid valve, and others.

HITER

HITER IND. E COM. CONTR. TERMO-HIDR. LTDA.
 Rua Capitão Francisco Teixeira Nogueira, 233
 CEP 05037-030 - Água Branca - São Paulo - Brasil
 Phone.: +55 11 3611.0788
 Fax: +55 11 3611.0921/3611.1711
 e-mail: vendas@hiter.com.br - www.hiter.com.br

Representative

Bulletin 1164 / Rev. July 2000