

PP SERIES PISTON ACTUATOR

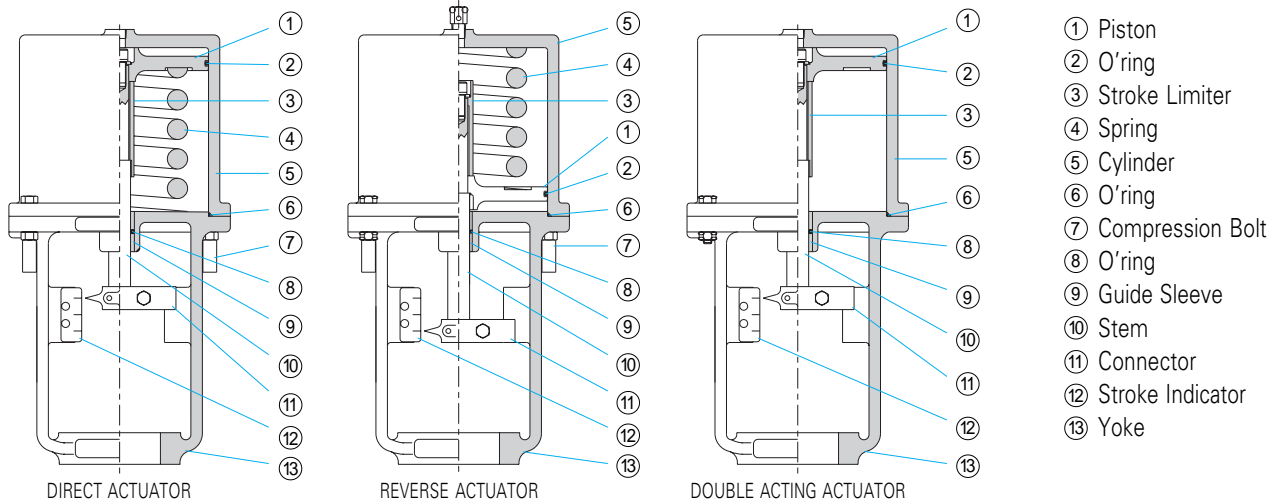

Main Parts Identification



Features

Table 1
Actuator
specifications

Operation

Linear pneumatic piston actuator.
Spring return or double acting.
Spring return units without handwheel
completely field reversible.

Air Pressure Supply

100 psig maximum.

Manual Operator (Optional)

Top handwheel for manual operation or stroke
limiting can be supplied.

Sizes and Strokes

See table 1. Other sizes are available on application.

Spring Range

Standard range: 25 - 50 psig.

SIZE	PISTON AREA (in. ²)	AVAILABLE STROKES (in.)
02	10.64	7/16
03	28	1/4, 3/8
04	50	3/4, 1.1/8, 1.1/2, 2
05	81	1.1/2, 2
06	133	2, 3, 4

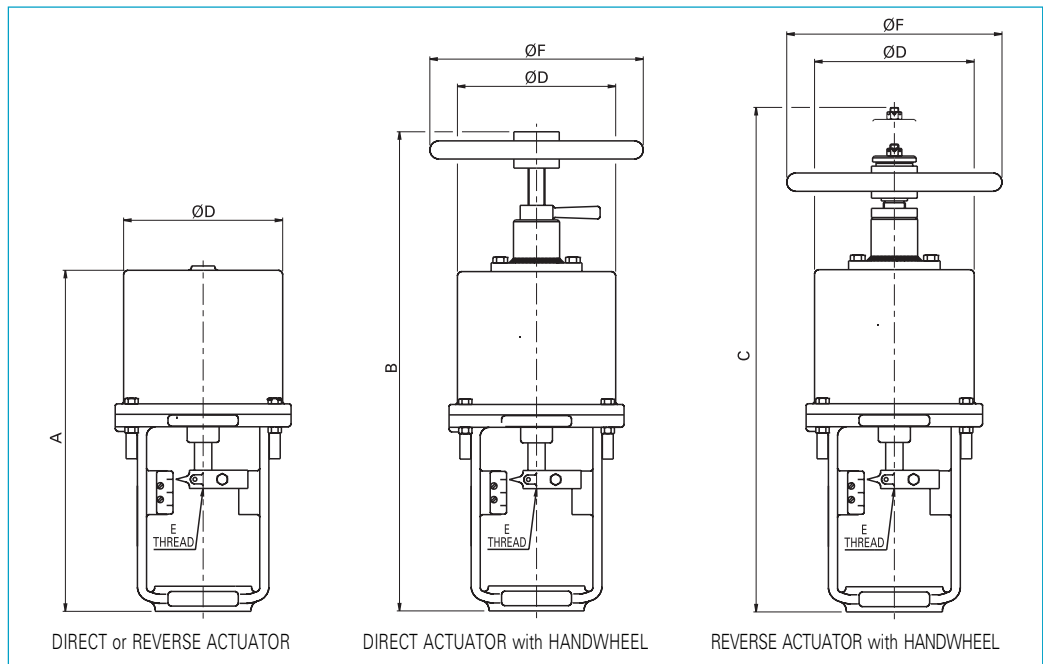

Table 2
Dimensions

SIZE	DIMENSIONS (mm)					
	A	B	C	ØD	E	ØF
02	186	307	367	108	1/4"-28UNF-2B	165
03	314	477	475	167	3/8"-24UNF-2B	235
04	444	644	656	219	1/2"-20UNF-2B	340
05	555	747	783	275	3/4"-16UNF-2B	480
06	780	-	-	360	1"-12UNF-2B	-

Accessories

Pneumatic positioner, electro-pneumatic positioner, smart positioner, air filter/regulator, limit switch, electro-pneumatic transducer, solenoid valve and others.

HITER

HITER IND. E COM. CONTR. TERMO-HIDR. LTDA.
Rua Capitão Francisco Teixeira Nogueira, 233
CEP 05037-030 - Água Branca - São Paulo - Brasil
Phone.: +55 11 3611.0788
Fax: +55 11 3611.0921/3611.1711
e-mail: vendas@hiter.com.br - www.hiter.com.br

Representative

Bulletin 1161 / Rev. July 2000